

Ensemble 3000 Series OpenVPX SCH3000 System Controller Hub

Application and System Management Control for 3U VPX Systems

- Supports control-plane and management-plane communications
- Provides application flexibility via GigE control-plane switch
- Enables sophisticated system management via industry-standard IPMI communications
- Architected to meet OpenVPX™ design principles

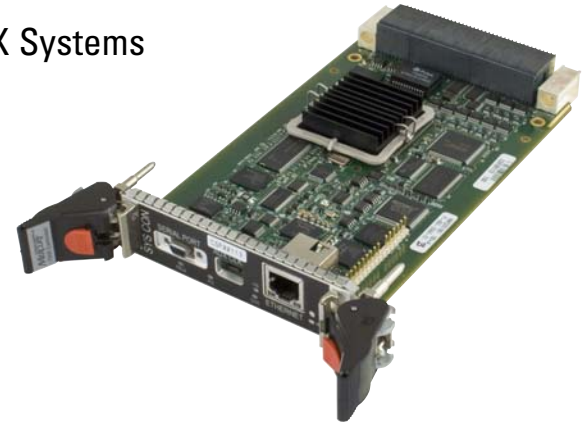

The Ensemble™ Series OpenVPX SCH3000 System Controller Hub (SCH) from Mercury Computer Systems is designed as a VITA 46 VPX-compliant module in a 3U form factor, also compatible with OpenVPX™ system architecture design principles. The SCH3000 plays a critical role within Mercury's scalable Ensemble 3000 Series 3U VPX Systems, providing mission critical system management and control. The SCH3000 functions as both a control plane Ethernet switch and a system management communications hub/controller.

Control-Plane Ethernet Switching

The Gigabit Ethernet control-plane switch enables application flexibility. Using a systems architecture with separate control and data planes allows applications to support a range of control functions without compromising or being affected by data-movement operations.

The control plane communications are supported by a Broadcom Gigabit Ethernet switch. The actual switching function is handled by an MIPS processor core integrated within the Broadcom chip. The interface to the backplane consists of eight SGMII ports to the eight VITA 46 slots. For component redundancy, a ninth port can be wired to another SCH3000 within the system. Ethernet communications to points outside the system are supported by a front panel connector (air cooled version only) and also via a backplane connector.

Sophisticated System Management

The intelligent system manager function within the SCH3000 performs the tasks accomplished in an ATCA® system by both a Carrier Management Controller and a Shelf Manager. The system management microprocessor on the SCH3000 provides voltage and temperature monitoring.

The system control is accomplished via communications over a dedicated management plane based on the Intelligent Platform

Management Interface (IPMI) standard, enabled by a Renesas IPMI Controller. Operating independently of both the control and data planes, there are IPMI communications lines from the SCH3000 to all payload, data-plane switch, power, and cooling modules within a system.

Ensemble 3000 Series 3U Systems

Each of the modules in Mercury's Ensemble 3000 Series 3U VPX product family was designed at the system level. The modules were designed to deliver optimized high-density, high-performance, real-time processing, tailored for use in applications with extreme space, weight, and power (SWaP) limitations. These systems are capable of being deployed in harsh environments, with both conduction-cooled and air-cooled options. The conduction-cooled version of the SCH3000 supports two-level maintenance (2LM).

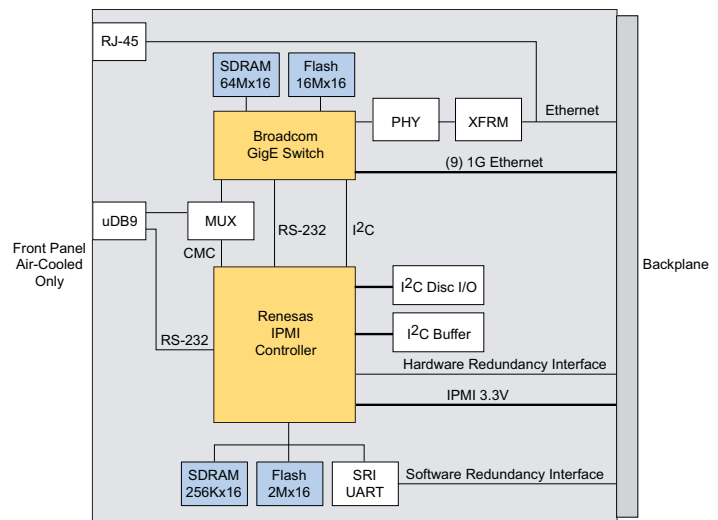

Figure 1. SCH3000 3U VPX System Controller Hub block diagram

Architected to support up to eight payload modules, Ensemble 3000 Series 3U VPX Systems can be configured with a variety of compute options including the Xilinx® Virtex™-5 LX-330T FPGA, and multi-core PPC processors such as the Freescale™ 1.067 GHz MPC8640D. System communications between these modules are partitioned into a Gigabit Ethernet control plane, an IPMI-based management plane, and a high-bandwidth RapidIO® data-plane switch fabric. This system architecture mirrors that of the Ensemble ATCA® and MicroTCA® systems.

Open Standards Means Interoperability and Planning for the Future

The OpenVPX™ Industry Working Group is an industry initiative launched by defense primes contractors and COTS System developers, to take a proactive approach to solving the interoperability issues associated with the VITA 46 (VPX) family of specifications. This group is actively collaborating to create an overarching System Specification defining VPX system architecture through pin outs definition to establish a limited set of Application specific reference solutions. These OpenVPX™ standard solutions will provide clear design guidance to COTS suppliers and the user community, assuring interoperability across multi-vendor implementations. The OpenVPX™ System Specifications will be introduced into the VSO for ratification to replace the current VITA 46 base and dot specifications in the fall of CY2009.

Specifications

Form factor 3U VPX

Broadcom Control-Plane Ethernet Switch

Internal MIPS Management Processor
10/100 Ethernet to Management Controller
10/100/1000 Base-T Ethernet to front panel (air-cooled only)
10/100/1000 Base-T Ethernet to backplane
(for out-of-the system connectivity)
RS-232 connection to front panel (air-cooled only)
Eight 1G SGMII Ethernet to VPX bays (embedded clock)
1G SGMII to redundant System Controller Hub (embedded clock)
RS-232 connection to Management Controller
MIPS32 300MHz core
16Mx16 FLASH
64Mx16 DDR SDRAM

Auxiliary Clock (AUX_CLK+/-)

M-LVDS front panel connector to backplane
Pass through or clock generator output
MMC controlled direction/source

Fabric Clock (REF_CLK+/-)

25-MHz spread spectrum M-LVDS clock to the backplane

Renesas IPMI Management Controller

10/100 Ethernet to control-plane Ethernet switch
2Mx16 flash
256Kx16 SRAM
Board temperature monitors
Board voltage monitors
I²C ports
Optional fabric slot
Optional redundant fabric slot
To each of the eight VPX payload slots
To backplane MMC FRU EEPROM
To redundant System Controller Hub
Optional dual redundant to power modules and cooling units
One additional unused port to backplane

Debug Features

On-board JTAG emulator connector to host and management processors
RS-232 connection to host and management processors

Some of Mercury's products are subject to the jurisdiction of the U. S. International Traffic in Arms Regulations (ITAR). Please contact your Mercury sales representative for more information.

Ensemble and Challenges Drive Innovation are trademarks of Mercury Computer Systems, Inc. RapidIO is a registered trademark of the RapidIO Trade Association. OpenVPX is a trademark of VITA. Other products mentioned may be trademarks or registered trademarks of their respective holders. Mercury Computer Systems, Inc. believes this information is accurate as of its publication date and is not responsible for any inadvertent errors. The information contained herein is subject to change without notice.

Copyright © 2009 Mercury Computer Systems, Inc. 2071.01E-0809-DS-3uvpx-sch3000



Corporate Headquarters

201 Riverneck Road
Chelmsford, MA 01824-2820 USA
+1 (978) 967-1401 • +1 (866) 627-6951
Fax +1 (978) 256-3599
www.mc.com

Europe

Mercury Computer Systems, Ltd.

Campbell Court, Unit 19 • Bramley, Tadley • HANTS RG26 5EG UNITED KINGDOM
+ 44 1 256 880090 • Fax + 44 1 25688 4004

Asia

Nihon Mercury Computer Systems K.K.

No. 2 Gotanda Fujikoshi Bldg. 4F • 5-23-1 Higashi Gotanda • Shinagawa-ku, Tokyo 141-0022 JAPAN
+81 3 3473 0140 • Fax +81 3 3473 0141

Challenges Drive Innovation™