

RACE++ Series PowerPC 7448 Multicomputer

High-Performance Product Upgrade

- 1.06-GHz and 1.26-GHz 7448 PowerPC options with double the L2 cache size over the 800-MHz 7447A previous generation
- Optional double-size main DDR DRAM vs. previous generation
- Increases application performance by 20-30%
- Ruggedized versions available
- Easy upgrade path with drop-in replacement and no application software changes needed

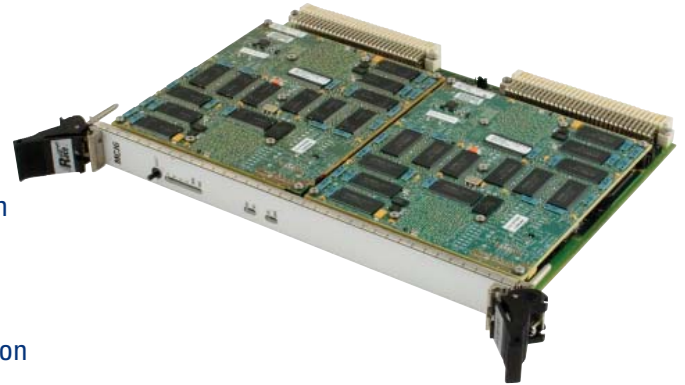

The RACE++[®] Series PowerPC[®] 7448 Multicomputer from Mercury Computer Systems is a high-performance drop-in product upgrade that adds significant improvements in processor speed, L2 cache size, memory available per processor, and application performance over the PowerPC MPC7447A. By maintaining commonality with previous RACE++ Series PowerPC products, Mercury provides an easy upgrade path for existing system designs.

MPC7448 PowerPC Processors with AltiVec

The PowerPC 7448 Multicomputer is available in 6U and 9U form factors:

- The 6U PowerPC 7448 Multicomputer consists of an MCJ6 motherboard and two daughtercards. Each daughtercard has either two 1.06-GHz MPC7448 processors or two 1.267-GHz processors with AltiVec™ technology. These processors combine a modern superscalar RISC architecture with an AltiVec parallel vector execution unit. MCJ6 configurations with one PowerPC 7448 daughtercard and one RINOJ-F-2.5 are also available.
- 9U MCJ9 configurations with up to seven PowerPC-7448 daughtercards and one RINOJ-F-2.5 are also available.

RACE++[®] Series PowerPC 7448 daughtercards combine 1.06-GHz or 1.267-GHz CPU with double data-rate (DDR) SDRAM with 512 MB or 1024 MB per MPC7448 on a standard Mercury Type J daughtercard for RACE++ VME systems. Targeted specifically for today's memory-bound applications, these daughtercards interface directly with the RACE++ switch fabric to form the optimal balance in processing, memory, and data communications attainable for embedded multicomputing applications.

Compute Node Architecture

The computational power of RACE++ Series systems is built from compute nodes (CNs) comprised of processors, memory, and interfaces to the RACE++ interconnect. PowerPC 7448 daughter-

cards contain two compute nodes, each consisting of an MPC7448 processor with AltiVec technology, a 1-MB fast on-chip Level 2 (L2) cache, DDR SDRAM, and a Mercury-designed CN interface chip.

The CN interface chip facilitates concurrency between arithmetic and I/O operations. Each PowerPC 7448 CN includes a fully pipelined on-chip L2 cache that delivers 32 bytes per clock cycle to the L1 caches.

High-Performance Memory System

Like the MPC7447A, the MPX processor bus used on the PowerPC 7448 daughtercards delivers key memory access and sustained throughput enhancements over the 60x bus used on earlier daughtercards. Mercury's high-performance memory subsystem allows the memory to approach the theoretical limits of its performance capability with:

- DDR-266 133-MHz double data-rate DRAM for additional bandwidth
- Virtual mapping registers for finer granularity of address mapping
- FIFO buffers that efficiently overlap access to SDRAM from the local processor and the RACEway[®] interconnect
- Error-checking circuitry for improved data integrity

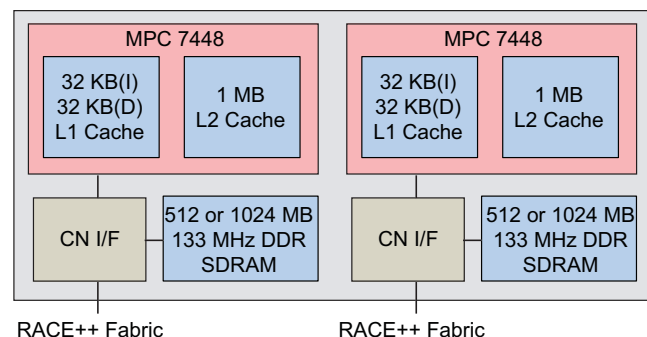

Figure 1. RACE++ Series PowerPC 7448 daughtercard compute node block diagram

RACE++ Switch Fabric Interconnect

The PowerPC 7448 daughtercard is fully compatible with the RACE++ interconnect, the second generation of the RACEway switch fabric interconnect. Like its predecessor, the MPC7447A, the PowerPC CN FPGA connects the processor and memory directly to the 66.66-MHz RACEway interconnect. The RACE++ interconnect represents the most cost-effective approach to utilizing the computational power of the newer PowerPC processors, providing unmatched scalability, high communication speed, more richly connected topologies, and augmented adaptive routing.

Software

Mercury provides programming tools that simplify development and testing of real-time applications. The RACE++ Series MULTI® Integrated Development Environment (IDE) enables programmers to use familiar, mainstream tools to develop real-time processing routines:

- The MULTI IDE's integrated debug, program build, profiling, and version control facilities streamline development of complex multiprocessor software.
- Scientific Algorithm Library (SAL) provides the industry's easiest method of accessing the full power of the AltiVec vector unit. The SAL contains hundreds of image and signal processing functions optimized for AltiVec execution.
- Parallel Acceleration System (PAS™) supports the DRI industry-standard data reorganization interface for a wide variety of efficient and scalable multiprocessor communication patterns using high-level library calls.
- Trace Analysis Tool and Library (TATL™) is a minimally intrusive software logic analyzer that allows developers to visualize multiprocessor interactions. Using TATL, developers can spot bottlenecks, such as contention for shared resources or load imbalances.

Some of Mercury's products are subject to the jurisdiction of the U. S. International Traffic in Arms Regulations (ITAR). Please contact your Mercury sales representative for more information.

RACE++ is a registered trademark, and PAS, TATL, and Challenges Drive Innovation are trademarks of Mercury Computer Systems, Inc. Other products mentioned may be trademarks or registered trademarks of their respective holders. Mercury Computer Systems, Inc. believes this information is accurate as of its publication date and is not responsible for any inadvertent errors. The information contained herein is subject to change without notice.

Copyright © 2009 Mercury Computer Systems, Inc.

1771.03E-1009-DS-7448_race

Specifications

PowerPC 7448 Daughtercard

	1.06-GHz	1.267-GHz
RACEway ports	2	2
Processor frequency	1.06-GHz	1.267-GHz
Compute nodes	2	2
Memory frequency	133 MHz	133 MHz
DDR DRAM per CN	512 MB or 1024 MB	512 MB or 1024 MB
DDR DRAM per daughtercard	1024 MB or 2048 MB	1024 MB or 2048 MB
L2 cache frequency	1.06-GHz	1.267-GHz
	(32 Bytes wide)	(32 Bytes wide)
L2 on-chip cache per CN	1024 KB	1024 KB

PowerPC 7448 Multicomputer

6U VME/RACE++ MCJ6 and 2 daughtercards*

	1.06-GHz	1.267-GHz
Maximum power consumption		
512 MB per CN	68W**	72W
1024 MB per CN	72W	76W

Environmental

The following specifications are for the 6U PowerPC 7448 Multicomputer for standard commercial environments. Mercury also offers the RACE++ Series PowerPC 7448 in various rugged environments.

For 1.06-GHz and 1.267-GHz

Temperature	
Operating	0°C to +40°C
Storage	-40°C to +85°C
Minimum airflow	12 CFM (512 MB per CN)
Operating altitude	0-10,000 ft***
Humidity	10 to 90% (non-condensing)
Vibration (random)	0.003g ² /Hz, 20-2000 Hz, 1 hr/axis
Vibration (shock)	z-axis: 20g, x+y axes: 32g, 11 ms, half-sine pulse

* Requires 5-row connectors and VITA 1.7-compliant (2 amp/pin) VME backplanes.

** The 1.06 GHz product consumes approximately 2W less than the 800 MHz/7447 version of the product in a comparable configuration.

*** Contact Mercury for operating altitude above 10,000 ft.

As altitude increases, air density decreases, hence the cooling effect of a particular airflow rating decreases. Many manufacturers specify altitude and temperature ranges that are not simultaneous. Note that the above operating temperature is specified simultaneously with an altitude. Different limits can be achieved by trading among altitude, temperature, performance, and airflow. Contact Mercury for more information.



Corporate Headquarters

201 Riverneck Road
Chelmsford, MA 01824-2820 USA
+1 (978) 967-1401 • +1 (866) 627-6951
Fax +1 (978) 256-3599
www.mc.com

Europe

Mercury Computer Systems, Ltd.

Unit 1 - Easter Park, Benyon Road • Silchester, Reading • RG7 2PQ UNITED KINGDOM
+ 44 0 1189 702050 • Fax + 44 0 1189 702321

Asia

Nihon Mercury Computer Systems K.K.

No. 2 Gotanda Fujikoshi Bldg. 4F • 5-23-1 Higashi Gotanda • Shinagawa-ku, Tokyo 141-0022 JAPAN
+81 3 3473 0140 • Fax +81 3 3473 0141

Challenges Drive Innovation™