

Ensemble 2000 Series MTI-104 Quad TI DSP AMC Module

TI DSP RapidIO® Application Development and Deployment

- Advanced performance for baseband development applications
- Robust application development infrastructure
- AdvancedTCA® AMC solution

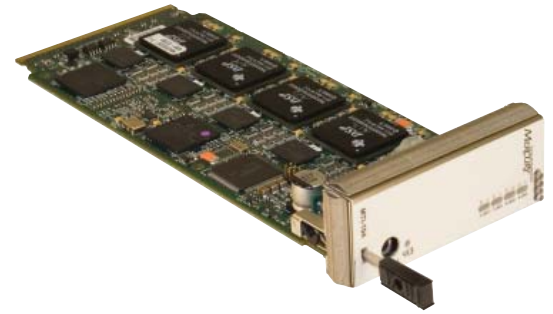

The Ensemble™ 2000 Series MTI-104 Quad TI DSP AMC module from Mercury Computer Systems is a full-height AdvancedTCA® (ATCA) AMC module that is designed for application development on four Texas Instruments (TI) TCI6482 RapidIO® DSPs, each operating up to 1.2 GHz core frequency. Application developers can immediately optimize their application code with the Quad TI DSP AMC module and get to market faster.

Module Features

The MTI-104 AMC is designed for insertion into any of the four AMC carrier sites on the Ensemble BCC-101 carrier board. The AMC module can be used for either RapidIO or Gigabit Ethernet applications. It has a Gigabit Ethernet switch to communicate among the DSPs, and 1x serial RapidIO infrastructure to each of the DSPs to support high-performance application development. The 1x serial RapidIO fabric connects the DSPs locally and off the AMC.

Each DSP has 64 MB of DDRII memory, running at 500 MB/s (250 MHz clock). A Flash interface is connected to one of the DSPs to bring up the module and then boot the other DSPs. The module comes complete with the necessary IPMI software to remotely power and monitor the board, and to interface with the carrier board and the shelf managers in the ATCA chassis.

The front panel has a set of LEDs to indicate the status the DSPs. Four IPMI LEDs are provided per the AMC specification. The LEDs are user-programmable to indicate DSP status or to test the infrastructure JTAGs that support programming and debugging of the application on the board.



Figure 1. MTI-104 faceplate

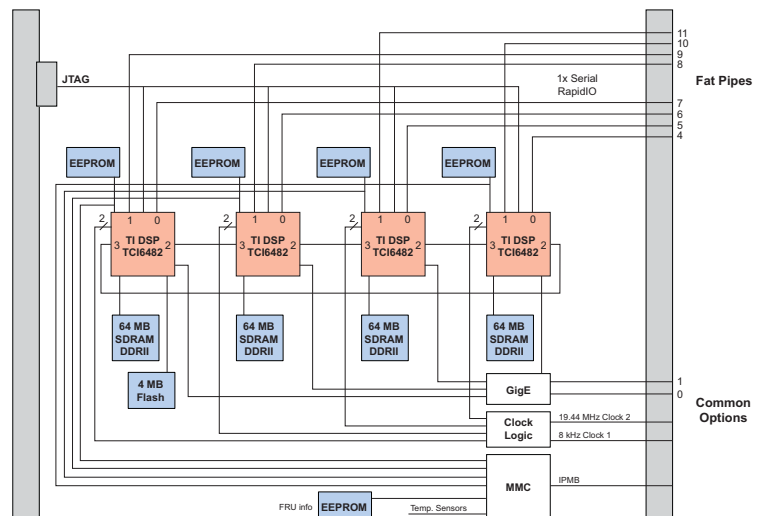

Figure 2. MTI-104 Quad TI AMC Module functional block diagram

Specifications

Four DSP nodes

Texas Instruments TMS320TCI6482 signal processor up to 1.2 GHz

Serial RapidIO interfaces

Four 1x serial RapidIO connections

1.25, 2.5, and 3.125 Gbps data rate support

EMIFA – Flash interface (connected on single node only)

4 MB Intel StrataFlash®

DDRII memory support (connected to all four DSPs)

64 MB Infineon® DDRII SDRAM

32 MB ×16-bit

250 MHz clock (1 Gbps data rate)

I²C EEPROM support

Power generation and distribution

12V payload power, 3.3V IPMI power

12V input dc-to-dc modules to supply 1.2V, 1.8V, and 3.3V

Linear regulator for 1.2V and 2.5V

Clock generation and distribution

25 MHz clock input reference for:

TMS320TCI6482 RGMII

TMS320TCI6482 DDRII

BCM5389 Gigabit Ethernet switch

BCM5466R Gigabit Ethernet transceiver

125 MHz clock input reference for TMS320TCI6482 serial RapidIO

50 MHz clock input reference for TMS320TCI6482 core

IPMI peripheral manager

Voltage monitor

Geographical address monitor

Temperature monitors

Power/reset control

DSP EEPROMS

FRU EEPROM

Status LED

Test/development

14-pin JTAG/emulator connector

ICT test points

Jumper plugs (configuration changes)

LEDs

Mechanical/dimensions

Compliant to AMC.0, Rev. 1.0

Width 28.96 mm

Depth 28.53 mm

Height 73.81 mm

Supports AMC B+ bays

Full-height AMC Single-width AMC

B+ edge connector

Supports hot swap

Four front-panel LEDs per AMC.0

Out of service (OOS) LED – red

User LED 2 (LED2) – green

User LED 3 (LED3) – yellow

Hot swap LED (H/S) – blue

Lower ejector handle switch Hardware address

Software support

DSP/BIOS™

OSEck™ (through third-party)

Environmental

Temperature

Operating 0°C to +55°C at 10,000 ft

Storage -40°C to +85°C

Humidity

Operating 10-90% non-condensing

Vibration 0.003g²/Hz, 20-2000 Hz, 1 hr/axis

Shock x and y axes: 32g; z axis: 20g; 11 ms, half-sine

Air flow 10 CFM per slot

Power consumption

12V payload power 30W max 20W typical

3.3V management power 0.5W max 0.25W typical

Some of Mercury's products are subject to the jurisdiction of the U. S. International Traffic in Arms Regulations (ITAR). Please contact your Mercury sales representative for more information.

Ensemble and Challenges Drive Innovation are trademarks of Mercury Computer Systems, Inc. RapidIO is a registered trademark of the RapidIO Trade Association. Other products mentioned may be trademarks or registered trademarks of their respective holders. Mercury Computer Systems, Inc. believes this information is accurate as of its publication date and is not responsible for any inadvertent errors. The information contained herein is subject to change without notice.

Copyright © 2009 Mercury Computer Systems, Inc.

478.04E-0909-DS-E2MT1104



Corporate Headquarters

201 Riverneck Road
Chelmsford, MA 01824-2820 USA
+1 (978) 967-1401 • +1 (866) 627-6951
Fax +1 (978) 256-3599
www.mc.com

Europe

Mercury Computer Systems, Ltd.

Campbell Court, Unit 19 • Bramley, Tadley • HANTS RG26 5EG UNITED KINGDOM
+ 44 1 256 880090 • Fax + 44 1 25688 4004

Asia

Nihon Mercury Computer Systems K.K.

No. 2 Gotanda Fujikoshi Bldg. 4F • 5-23-1 Higashi Gotanda • Shinagawa-ku, Tokyo 141-0022 JAPAN
+81 3 3473 0140 • Fax +81 3 3473 0141

Challenges Drive Innovation™