

# Precision Control

## Application

Precise control of moving equipment is required across a range of industries, including semiconductor equipment, wire bonders, nanotechnology, and some defense applications. In many such applications, the throughput of the equipment is a key feature, so high speed is required as well as precision.

## Problem

Where high precision and high speed are required at the same time, complex control algorithms are needed, which cannot be effectively implemented on a single processor. Deterministic latency from sensor input to actuator demand is critical to correct operation of the equipment. The processing sub-system, therefore, requires deterministic, low-latency communication throughout the processing chain.

## Application Data Flow

Sensor input may be analog, digital, or a mix, depending on the sensor types used and precision required. Multi-axis systems often need to address cross-coupling between the axes. To provide the level of precision required for semiconductor and nanotechnology applications, the algorithms must also account for temperature and other environmental effects.

## Solution

Using a switch fabric to connect processors avoids the timing and contention issues associated with a shared bus and allows processing and I/O to be easily scaled. The serial RapidIO® switch fabric is designed specifically for embedded applications and, as such, has excellent determinism. It can support a broad range of processors, and the endpoint has a small enough footprint to be implemented in an FPGA. The flexibility provided by a network of processors connected over a RapidIO fabric supports task decomposition and aggregation across processors to suit performance and cost requirements.

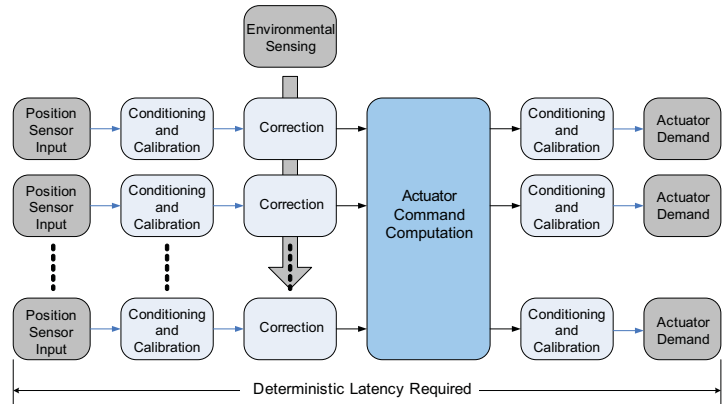

Figure 1. Block diagram of precision control application functions

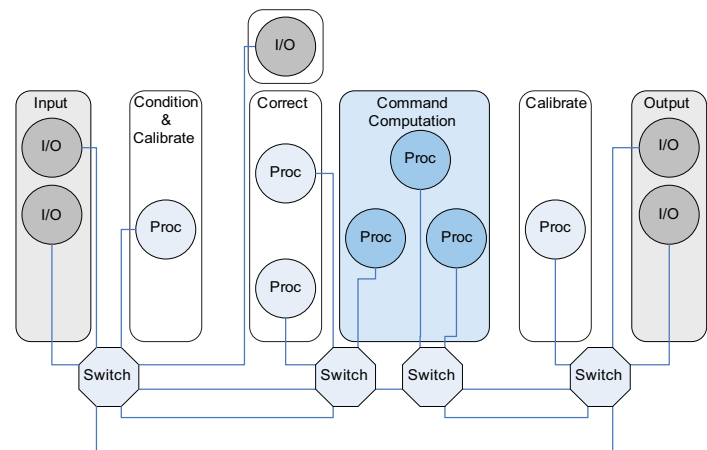

Figure 2. Mapping application functions to computing components

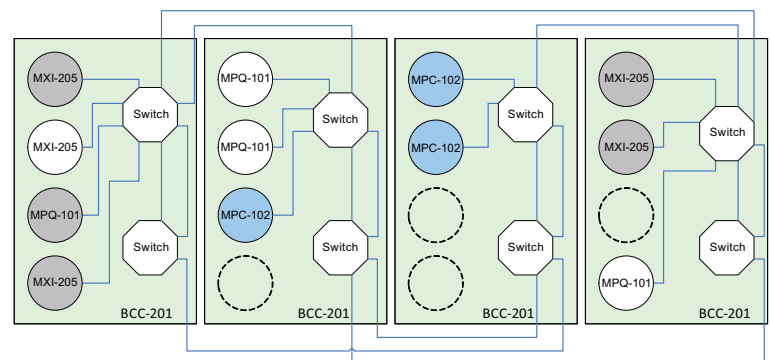

Figure 3. Computing components in an ATCA system architecture

## Implementation

AdvancedTCA® and MicroTCA® solutions provide a cost-effective, scalable architecture for implementing precision control processing systems. Ensemble™ 8000 processing platforms are used for semiconductor applications, while Ensemble 2000 platforms provide a lower price entry point for less demanding applications.



**Figure 4.** Ensemble 8000 Series 5-Slot ATCA Platform

## Added Benefit

Many of the systems implementing precision control applications are forms of industrial automation. In this class of equipment, the ability to remotely monitor the processing system, with early identification when machine health problems occur, can significantly reduce operating costs. The shelf management capability that forms an integral part of ATCA/MicroTCA platforms is extremely beneficial in these applications.

Some of Mercury's products are subject to the jurisdiction of the U. S. International Traffic in Arms Regulations (ITAR). Please contact your Mercury sales representative for more information.

Ensemble and Challenges Drive Innovation are trademarks of Mercury Computer Systems, Inc. RapidIO is a registered trademark of the RapidIO Trade Association. Other products mentioned may be trademarks or registered trademarks of their respective holders. Mercury Computer Systems, Inc. believes this information is accurate as of its publication date and is not responsible for any inadvertent errors. The information contained herein is subject to change without notice.

Copyright © 2009 Mercury Computer Systems, Inc.

2275.00E-0709-SM-prec-ctrl



### Corporate Headquarters

201 Riverneck Road  
Chelmsford, MA 01824-2820 USA  
+1 (978) 967-1401 • +1 (866) 627-6951  
Fax +1 (978) 256-3599  
www.mc.com

### Europe

#### Mercury Computer Systems, Ltd.

Campbell Court, Unit 19 • Bramley, Tadley • HANTS RG26 5EG UNITED KINGDOM  
+44 1 256 880090 • Fax +44 1 25688 4004

### Asia

#### Nihon Mercury Computer Systems K.K.

No. 2 Gotanda Fujikoshi Bldg. 4F • 5-23-1 Higashi Gotanda • Shinagawa-ku, Tokyo 141-0022 JAPAN  
+81 3 3473 0140 • Fax +81 3 3473 0141

*Challenges Drive Innovation™*