

# Ensemble 5000 Series VXS HCD5220 Module

## Balanced I/O and Processing in a Single VXS Payload Slot

- VITA 41 (VXS) 6U serial RapidIO®-enabled air-cooled module
- Two dual-core MPC8641D processors at up to 1.33 GHz
- Balanced processing and I/O
- Identical software infrastructure across Mercury products
- Flexible I/O supported on dual PMC/XMC sites



The Ensemble™ 5000 Series VXS HCD5220 Dual 8641D Dual-Core Processing Module from Mercury Computer Systems combines high-performance Power Architecture™ processing technology with balanced I/O from dual PMC/XMC sites and the scalable serial RapidIO® interconnect. Designed to meet the needs of a variety of applications, the HCD5220 can function as a single-board computer or as part of an embedded processing cluster for high-end digital signal processing. The HCD5220 is supported by the rich set of features available from the cross-product MultiCore Plus® software infrastructure, which allows for ease of portability while offering an open software development architecture.

### Power Architecture Processor

The Freescale™ MPC8641D dual-core processor integrates two standard e600 processor cores, two DDR2 memory controllers, 1 MB of L2 cache, and a flexible System-on-Chip I/O subsystem. The dual e600 cores that make up the heart of the chip are inherited from the 7448 processor, and each retains the high-performance AltiVec™ vector processing unit. Algorithms optimized for the AltiVec engine port seamlessly to the 8641D. Increased bandwidth between both memory and external I/O and the processing cores allows for efficient processing beyond that available with prior families of Freescale processors.

### Mezzanine Card Flexibility

Each of the standard PMC/XMC sites can be configured with off-the-shelf mezzanine cards using either PCI-X or PCI Express® protocols. PMC cards are supported with a PCI/PCI-X interface at up to 133 MHz on the primary site, and up to 100 MHz on the secondary site. PMC user-defined I/O is mapped to the backplane on one of the two PMC sites. XMCs are supported with x8, x4, x2, and x1 PCIe mezzanine cards per the VITA 42.3 standard. The XMC site can also be factory configured to support x1 or x4 serial RapidIO mezzanine cards per the VITA 42.2 standard.

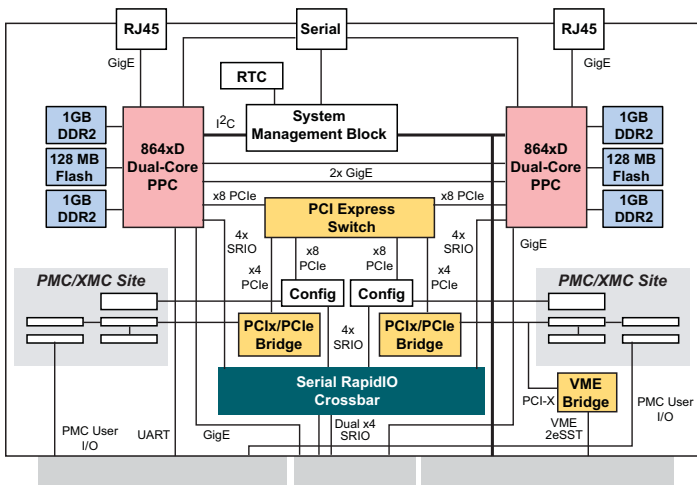

Figure 1. HCD5220 functional block diagram

## Open System Standards

The HCD5220 employs three independent standards-based communication planes for data input and movement, application control, and system management:

- **ANSI/VITA 41.2: VXS Serial RapidIO Interconnect**

The onboard serial RapidIO fabric enables communication with other system modules via the VXS P0 connector. Two x4 serial RapidIO links support data transfers at either 2.5 or 3.125 Gbaud, depending on system configuration.

- **ANSI/VITA 41.6: Gigabit Ethernet**

Gigabit Ethernet is supported at the front panel and via the VXS backplane interface. Each 8641D processor provides a front-panel 10/100/1000Base-T connection via the standard RJ-45 connector. Additionally, each processor provides a separate Gigabit Ethernet interface to the VXS P0 connector compliant with the draft VITA 41.6 (Control Plane) standard. A combined total of 4 Gigabit Ethernet links, enabled by the 8641D system-on-chip interface, are available on each HCD5220 module.

- **ANSI/VITA 38: System Management Bus**

The HCD5220 implements an onboard system management block, allowing any HCD5220 module in the system to perform remote queries on sensor values, set sensor thresholds, reset local and remote processors, and manage firmware updates. This management plane is implemented in accordance with the VITA 38 System Management Bus specification, implementing an I<sup>2</sup>C bus over the VME P1 connector.

## Additional Features

The HCD5220 provides the many features typically found on a single-board computer. In addition to the sophisticated management subsystem and fabric interconnect, the HCD5220 provides users with a toolkit enabling many different application use cases.

Features include:

- 128 MB of write-protectable boot/application flash per processor with protected boot vector to avoid accidental erasure
- Thermal and voltage sensors integrated onboard
- System management block capable of managing firmware updates, reading and writing sensor thresholds, reading sensor values, and resetting the module
- RS-232 serial interface ports per processor to the front panel with an additional interface optionally routed to the backplane
- Real-time clock with granularity to 1 ms and time measurement of up to 30 years
- General-purpose timers for synchronization
- Watchdog timer able to interrupt each processor upon expiration
- Open board architecture that supports network booting, as well as booting from the onboard flash memory

## Open Software Environment

For over 25 years, Mercury has been leveraging multicomputer software expertise, including recent multicore processor expertise, across its many platforms. This strategy is fully applied to the HCD5220. Because the processor, memory, and surrounding technologies are leveraged across product lines, software developed on the HCD5220 can interface seamlessly with other Mercury products. The same Linux® development and run-time environment is implemented on the HCD5220 as on other Mercury systems, such as the Ensemble 7100 and the VPA-200P.

The open software environment gives the HCD5220 access to a wide ecosystem of stacks, middleware, libraries, and tools. The Scientific Algorithm Library (SAL) is optimized for the onboard Altivec engine, giving the HCD5220 industry-leading signal processing performance. A key new software package available for the HCD5220 is MultiCore SAL (MCSAL), which has the familiar SAL API interfaces, but is optimized for the multiple on-chip cores available with the 8641D.

Software support is available on the HCD5220 for the following products:

- **Open Development Suite for Linux**

This Eclipse-based integrated development environment (IDE) includes a C/C++ optimizing compiler, a source level debugger, a language sensitive text editor, a performance profiler, a project builder, a version control system, a run-time error checker, and a graphical source browser. Mercury extensions allow multiprocessor-aware process launching and debugging, as well as a System Supervisor view for graphical remote management.

- **Trace Analysis Tool and Library (TATL™)**

This “logic analyzer for software” provides insight into the dynamic interaction of up to a few hundred processors.

- **VSIPL and SAL (Scientific Algorithm Library)**

Support for these Mercury standard numeric libraries is optimized for the 8641D architecture of the HCD5220.

- **Interprocessor Communication System (ICS)**

Support is carried forward from the RACE++®/MCOE™ software environment. ICS provides a low-level interprocessor communication API, enabling users to take advantage of the high-bandwidth, low-latency serial RapidIO fabric with an easy-to-use software interface.

- **Performance Porting Package**

Provides low-level handles for manipulation of the serial RapidIO fabric and may be used for simple data movement or as a base to build a custom middleware layer.

With MultiCore Plus (MCP) software, applications can use industry-standard middleware such as MPI, DRI, CORBA, or even standard TCP/IP sockets ported to run seamlessly over the fabric. MCP also offers a software tool that can help to migrate legacy applications created with MCOE into the MCP domain.

## Specifications

### Module

Two dual-core MPC8641D processors

Two PMC/XMC sites

XMC factory-selectable for PCI Express or serial RapidIO connectivity

Air-cooled

Input voltage 5V and 3.3V

---

### Processor Node

Dual-core 8641D Up to 1.33 GHz

Cores per device 2

DDR2 SDRAM Up to 2 GB per processor at up to 533 MHz

---

### PMC-X / XMC Sites

Two PMC-X sites

PCI-X-to-PCI Express bridge

Connects PMC sites to onboard PCI Express switch

PCI support at 33 MHz and 66 MHz

PCI-X support

Primary site 66, 100, and 133 MHz

Secondary site 66 and 100 MHz

PMC user-defined I/O from P4 to VME P2

PCI Express XMC sites per VITA 42.3 or serial RapidIO XMC sites per VITA 42.2

---

### VME Interface

2eSST capable via Tundra® TSi148™

---

### I/O

Two front-panel 10/100/1000Base-TX Ethernet ports

Two backplane Gigabit Ethernet ports per VITA 41.6

RS-232 serial interfaces per processor to front-panel interface

Additional serial interface optionally routed to backplane

---

### Additional Resources

Onboard 128-MB boot/application flash per processor

Real-time clock

Watchdog timer

General-purpose 32-bit timers/counters

System management block

Thermal and voltage sensors

---

### Environmental

Temperature

Operating 0°C to 40°C

Storage -40°C to +85°C

Altitude

Operating 10,000 ft

Storage 30,000 ft

\*CFM

20 (at sea level)

Humidity

10-90% non-condensing

Vibration

0.003g<sup>2</sup>/Hz, based on 20-2000 Hz, 1 hr/axis

Shock

z-axis: 20g; x-, y-axes: 32g; 11 ms half-sine;

3-positive and 3-negative on each axis

Rugged options

Consult factory.

\* As altitude increases, air density decreases and, therefore, the cooling effect of a particular number of CFM decreases. Different limits can be achieved by trading among temperature, altitude, frequency, and airflow. Consult factory for additional information.

---

Some of Mercury's products are subject to the jurisdiction of the U. S. International Traffic in Arms Regulations (ITAR). Please contact your Mercury sales representative for more information.

MultiCore Plus is a registered trademark, and Ensemble and Challenges Drive Innovation are trademarks of Mercury Computer Systems, Inc. RapidIO is a registered trademark of the RapidIO Trade Association. Other products mentioned may be trademarks or registered trademarks of their respective holders. Mercury Computer Systems, Inc. believes this information is accurate as of its publication date and is not responsible for any inadvertent errors. The information contained herein is subject to change without notice.

Copyright © 2009 Mercury Computer Systems, Inc.

1861.02E-1109-DS-vxshcd5220



**Corporate Headquarters**

201 Riverneck Road  
Chelmsford, MA 01824-2820 USA  
+1 (978) 967-1401 • +1 (866) 627-6951  
Fax +1 (978) 256-3599  
[www.mc.com](http://www.mc.com)

**Worldwide Locations**

Mercury Computer Systems has R&D, support and sales locations in France, Germany, Japan, the United Kingdom and the United States.

For office locations and contact information, please call the corporate headquarters or visit our Web site at [www.mc.com](http://www.mc.com).

*Challenges Drive Innovation™*