

# 1U Dual Cell-Based System 2

## Flexible Computing Solution Based on the Cell BE Processor

- Outstanding performance for HPC applications
- Designed for distributed processing
- Optional Cell-optimized software for enhanced application performance and developer productivity



The 1U Dual Cell-Based System 2 from Mercury Computer Systems is a flexible solution based on the Cell Broadband Engine™ (BE) processor. This solution significantly improves performance for computationally intensive high-performance computing (HPC) applications in medical imaging, industrial inspection, aerospace and defense, seismic processing, telecommunications, and other industries. Performance scales dramatically when the application is distributed across multiple 1U Dual Cell-Based Systems 2 in a cluster or across the network.

### Superb Performance

The 1U Dual Cell-Based System 2 has two Cell BE processors. For the first time, the power of dual Cell BE processors can be unleashed for applications that demand a low acoustic signature along with the added density of the 1U form factor. Each processor running at 3.2 GHz has 205 single-precision GFLOPS in the SPE (synergistic processing element) array, for a total of 410 GFLOPS of performance on the system. Mercury has mapped key signal processing algorithms onto the system, significantly increasing the performance advantages for HPC applications.

### Multicomputer-on-a-Chip

The Cell BE processor architecture is essentially a multicomputer-on-a-chip. This architecture of heterogeneous high-performance processing elements on a common interconnect has a structure that is designed for distributed processing. The Cell BE processor includes three main functional components:

- The Power™ processing element (PPE) has dual hardware multi-threading and a standard VMX vector processing engine. It has separate 32 KB L1 data and instruction caches and 512 KB of L2 cache.

- In the array of eight SPEs, each has a dual-issue pipeline, a 128-bit-wide vector processing engine, a large register set (128 registers, each 128 bits wide), and 256 KB of local store (LS). Each SPE accesses system memory via its memory flow controller (MFC), which is a high-performance DMA engine.
- A high-speed data ring called the element interconnect bus (EIB) consists of two pairs of counter-rotating rings with a sustained aggregate bandwidth of 205 GB/s.

Additionally, each chip has high-bandwidth, low-latency memory and I/O interfaces.

The Dual Cell-Based System 2 has two Cell BE processors operating in SMP mode with full cache and memory coherency. The EIB is extended transparently across a high-speed coherent interface running at 20 GB/s in each direction between the two Cell BE processors.

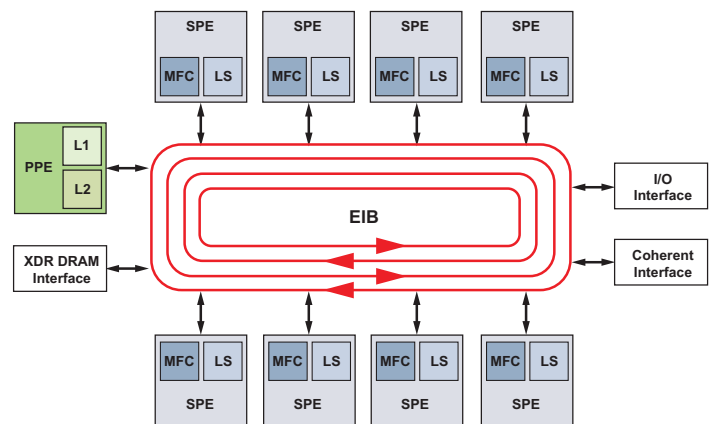

Figure 1. Cell Broadband Engine Processor block diagram

## 1U Dual Cell-Based System 2 Topology

The 1U Dual Cell-Based System 2 has two Cell BE processors, providing multiprocessing capabilities. Two companion chips provide the high-speed bridges from the processors to two PCI Express® x8 channels and two Gigabit Ethernet interfaces. The system can optionally support a SAS magnetic or flash disk that can provide a boot mechanism for the operating system and support for two optional PCIe® full-size plugin cards. Front-panel features include local power control, soft reset, and LEDs for power, alert, and status information. The serial interface is also accessible via the front of the system.

## High-Speed Memory

The XDR™ DRAM device architecture allows the highest sustained bandwidth for multiple, interleaved randomly addressed memory transactions. This highly efficient protocol yields over 95% utilization while allowing fine access granularity. The 1U Dual Cell Based System 2 includes 1 GB of XDR DRAM per Cell BE processor.

In addition, two DDR2 DIMM sockets are attached to each companion chip supporting up to 1-GB DIMMs each. The system can support a total of up to 6 GB of memory.

## PCI Express Interface (Optional)

PCI Express is a high-speed serial interface with a packet-based protocol. The PCI Express interface allows the companion chips to interconnect to two mechanical x16 electrical, x8 full length, full height PCIe slots.

## Gigabit Ethernet

The Gigabit Ethernet adapter on each companion chip is connected to the chassis external ports.

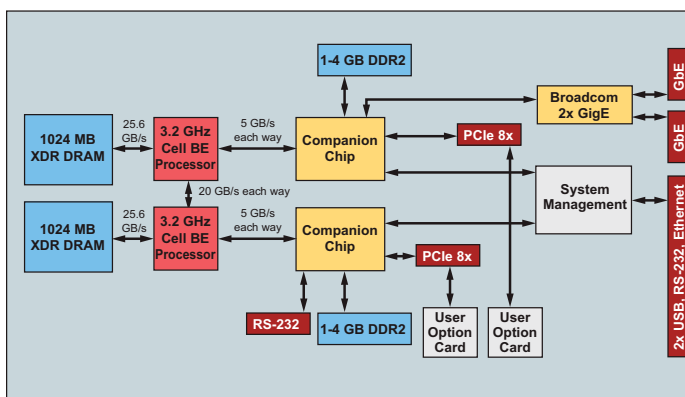

Figure 2. 1U Dual Cell-Based System 2 block diagram

## MultiCore Plus SDK (Optional)

The MultiCore Plus SDK (Software Development Kit) is an option available for the Dual Cell-Based System 2. This suite of software products is specifically designed for next-generation multicore processors such as the Cell BE processor. The SDK includes a comprehensive programming framework, highly optimized math libraries, and plugins that integrate the MultiCore Plus software with the IBM IDE, based on the Eclipse IDE.

**MultiCore Plus™**

The focus of the MultiCore Plus SDK is application performance and developer productivity. This seamless package of software development tools and libraries helps you take full advantage of the Cell BE processor's architecture to maximize your application's resources and boost performance.

The Ready for IBM Technology Mark certifies that the MultiCore Plus SDK has met IBM-specified standards for compatibility with IBM Microelectronics products and services. Ready for IBM Technology solutions are designed to help original equipment manufacturer (OEM) customers speed time to market, reduce development risk, lower development costs, and improve return on investment.

## Serviceability Features

Serviceability features include hardware verification during module initialization, an onboard systems-management processor, and a chassis management module. Optional Linux®-based diagnostics verify the correct operation of the system.

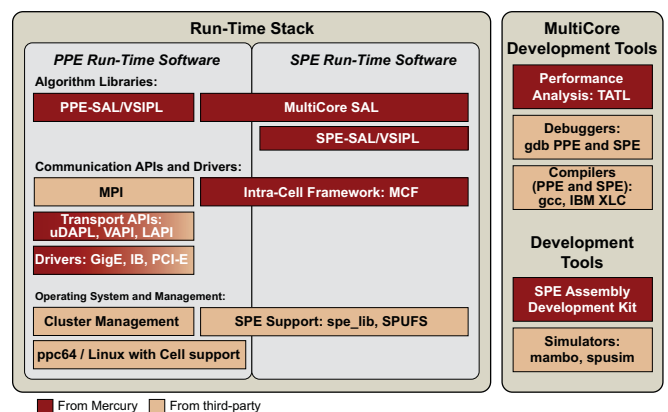

Figure 3. MultiCore Plus SDK software stack

## Mercury Support Services

Mercury's broad range of enhanced support services augment your internal capabilities and increase your effectiveness. For example:

- Installation and upgrade services span the entire installation process from site planning through onsite installation and certification to post-installation upgrade configuration and testing.
- End-to-end network integration services start with a requirements assessment, include network integration design tailored to your environment, and culminate with the installation and configuration of your total system.
- Flexible product training offerings include one-on-one or classroom setup in small or large groups, with either instructor-led or learn-on-demand format for introductory or advanced classes, refresher training, or certification.
- The self-service maintenance program trains and certifies you to use quick-fix scripts and easy-to-follow instructions, diagrams, and videos to help you perform your own maintenance with spares kits for fast repair and customer-replaceable units.
- On-going maintenance and repair services include remote and onsite support packages tailored to your business needs, standard and extended technical support coverage, and guaranteed response times and parts replacement.

## Specifications

### Dual Cell BE Processors

PPE core	IBM® 64-bit Power Architecture™
L1 cache size	32 KB instruction; 32 KB data
L2 cache size	512 KB
SPEs	8
Local store	256 KB
Registers	128 x 128 bits wide
EIB	205 GB/s sustained aggregate bandwidth
Processor internal clock speed	3.2 GHz
Processor-to-memory bandwidth	25.6 GB/s
Processor-to-processor coherent interface	20 GB/s in each direction

### Memory

XDR memory	
Each processor	1 GB, 3.2-GHz XDR DRAM, 2 channels per processor
DDR2 memory	
Each processor	1 or 2 GB, 667-MHz DDR2 organized as 2 VLP DIMMs per processor, 1 channel per DIMM (optional)
ECC support	Single-bit correct; double-bit detect on XDR and DDR2
Flash	32 MB
NVRAM	1 MB

### Hard Disk (Optional)

Hard disk controller	SAS Controller via PCIe plugin card (consumes one slot)
Number of hard disks	1 (maximum)

### I/O Subsystems

Serial ports	2 (one dedicated for management functionality)
USB ports	2
Ethernet ports	2 10/100/1000 Mb
Supports advanced RAS system management via a dedicated Ethernet connection.	
InfiniBand® option	
10 Gigabit Ethernet option	

### Expansion Options (Optional)

Plugin cards	2 PCIe x16 mechanical, x8 electrical full-size cards 25W maximum; consult factory for higher power cards.
PCIe extender	

### System Management

System Management Module	
Baseboard Management Controller	

### MultiCore Plus SDK Software (Optional)

(32/64-bit application support)

MCF (MultiCore Framework)	PPE/SPE
TATL™ (Trace Analysis Tool and Library)	PPE/SPE
SAL (Scientific Algorithm Library)	PPE/SPE
PixL™ (Image Processing Algorithm Library)	PPE
MCPDIAGS (MultiCore Plus Diagnostics)	PPE/SPE
SPEAD-K (SPE Assembly Development Kit)	SPE
Linux operating system	

### Size

Length	30 in
Width	17.15 in (19-inch EIA rackmount)
Height	1.73 in (1U)

Airflow	Required	<90 CFM @ MSL
---------	----------	---------------

Noise	Acoustical noise	<50 dBA @ 1 m
-------	------------------	---------------

Electrical	100-240VAC, 50/60 Hz
------------	----------------------

### Power Consumption

Maximum	700W
Typical	575W

Weight	<45 lb
--------	--------

### Environmental

Ambient temperature	0°C to 35°C
Humidity	5-80% non-condensing
Altitude	7000 ft at 32°C

\*Maximum ambient temperature is de-rated to 32°C beginning at 3000 ft.

### Compliance

European Directive 2002/95/EC	(RoHS 5/6 Server Exemption Directive)
Safety	UL/EN/IEC 60950-1 (intended)
EMC	EN 55022, EN 61000, EN 55024:1998, FCC Class

MultiCore Plus, Pixl, TATL, and Challenges Drive Innovation are trademarks of Mercury Computer Systems, Inc. Cell Broadband Engine is a trademark of Sony Computer Entertainment, Inc. The Ready for IBM Technology mark and the trademarks contained therein are trademarks of IBM Corp. IBM is not the licensor of this Business Partner's product and does not make any warranties regarding this Business Partner's product. Other products mentioned may be trademarks or registered trademarks of their respective holders. Mercury Computer Systems, Inc. believes this information is accurate as of its publication date and is not responsible for any inadvertent errors. The information contained herein is subject to change without notice.

Copyright © 2007 Mercury Computer Systems, Inc.

1296.00E-0807-DS-1Udcbs2



#### **Corporate Headquarters**

199 Riverneck Road  
Chelmsford, MA 01824-2820 USA  
+1 (978) 967-1401 • +1 (866) 627-6951  
Fax +1 (978) 256-3599  
[www.mc.com](http://www.mc.com)

#### **Worldwide Locations**

Mercury Computer Systems has R&D, support and sales locations in France, Germany, Japan, the United Kingdom and the United States.

For office locations and contact information, please call the corporate headquarters or visit our Web site at [www.mc.com](http://www.mc.com).